

FUTERA^{XL}LF

Double The Power

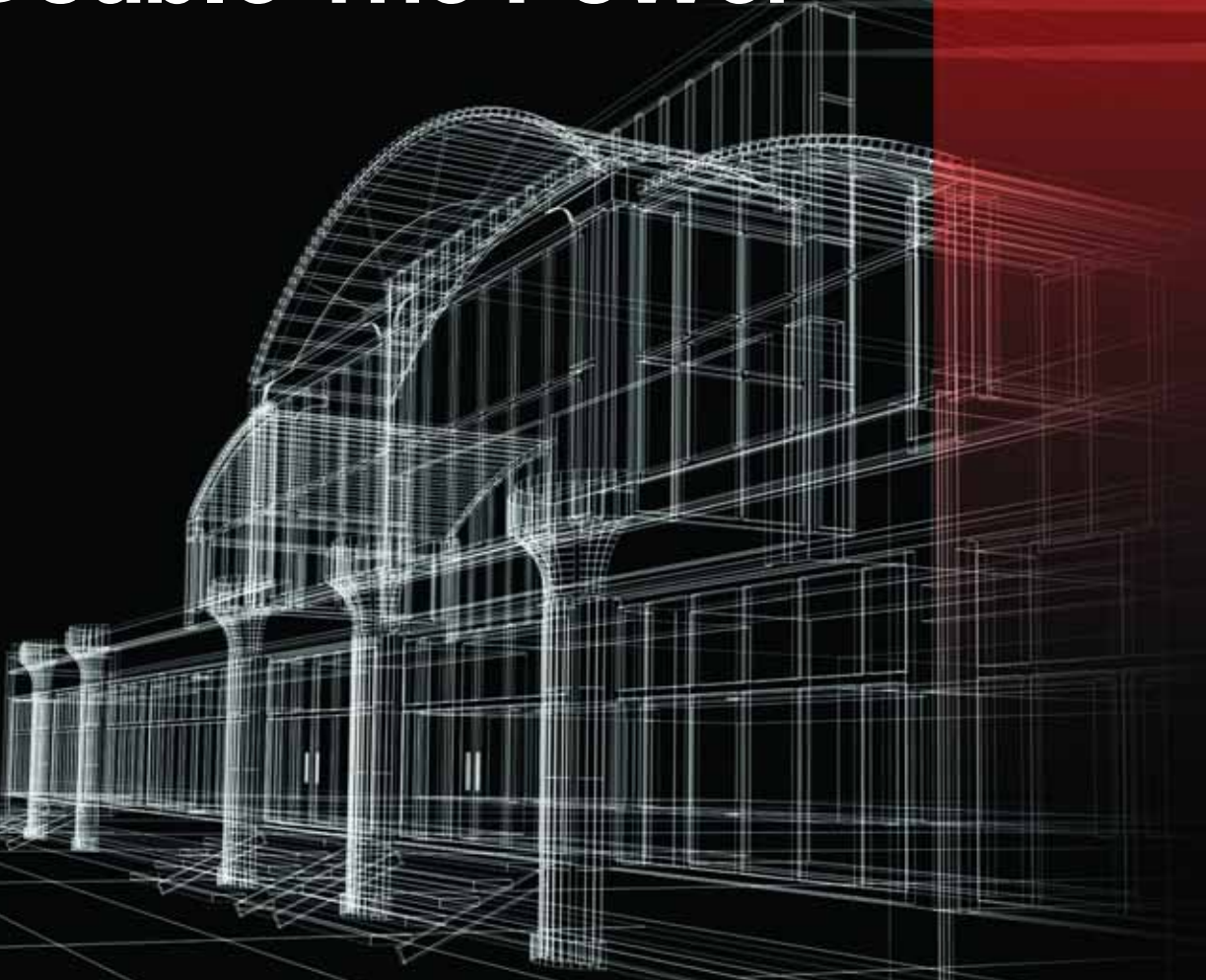

RBI[®]



Efficient Power, Sized to Your Vision

The Futera XLF is designed with 5-to-1 turndown, up to 88% efficiency, and backed by RBI reliability and ease of service. Those are just a few of the ways we are helping you solve today's commercial design challenges. And having double the power in the same compact dimensions — width, depth, and height — doesn't hurt either.

The XLF features integral HeatNet® control that can act as a boiler management system, networking up to sixteen units without requiring any external control panel. Such advanced performance in such a small space can benefit older boiler systems by adding contemporary efficiency for either heating systems or domestic hot water. For new construction, XLF

makes possible a modular configuration that is unmatched for output relative to size. It can even be networked with other boiler types, including condensing units: adding XLF to a condensing installation can reduce the number of condensing units required to meet load during peak heating months, when condensing units' efficiency drops. This application, called base loading or front-end loading, can significantly reduce first costs without compromising fuel consumption.



Smart Controls, Simplified Diagnostics

The Futera XLF comes standard with HeatNet on board, ready on installation for a variety of configurations: stand-alone, part of a Master/Member network using HeatNet protocol, member in a system for up to 16 boilers, or linked to a BMS. HeatNet maximizes turndown rates to maintain peak efficiency utilizing four temperature sensor inputs: outside air, supply (outlet) temperature, return (inlet) temperature, and header temperature. It eliminates wall-mounted control panels and offers an easy-to-read display and intuitive control menus.



Easy access to control and diagnostic components speeds installation and service



XLF simplifies service with a special manometer diagnostic port that allows technicians to take multiple pressure readings from a single connection: pilot gas, pilot air, rate signal, and feedback

Four-button touchpad with plain-English display and intuitive menus simplifies programming and diagnostics

Rugged & Reliable: The Turbo Pilot

Another investment in the reliable performance that's built into the XLF is its patent-pending Turbo Pilot system. Far more durable than any Hot Surface Ignition and more robust than a simple direct spark system, the Turbo Pilot gives burner ignition a sure, powerful source. UV detection keeps system diagnostics informed about performance; a technician can also use the observation port to confirm spark/flame without removing the pilot or burner assembly. And if maintenance does need to be performed, a few seconds is all that's needed to pull, clean, or adjust the pilot.





Big-Time Components, Small Diameter Vent

Like all RBI products, the Futera XLF is built with the highest-grade components and materials. The heat exchanger's solid bronze headers prevent rust and corrosion for the life of the unit. XLF's symmetric air/fuel coupling provides a high degree of safety while ensuring consistent combustion quality regardless of changes to fuel or air flow. In addition to its compact dimensions enabling 3 or 4 million Btuhs to be installed in a small space, its small vent diameter is easy to work with and reduces vent material costs. Removal of top and front panels is simple, streamlining installation and service.

Whether to add efficient low-demand output to a larger existing system, or to build a highly space- and energy-efficient heat and hot water system from the ground up, the RBI Futera XLF gives you the power to develop a solution that fits any design.

FUTERA^{XLF}

STANDARD FEATURES

- 3,000 – 4,000 MBH
- Finned copper tube heat exchanger, ASME 160 psi max WP, 4-pass design
- Stainless steel jacket panels
- Solid bronze headers
- Variable speed blower
- Digital text annunciator
- Mounted & wired flow switch
- Mounted & wired low water cutoff
- Quick-release service latches
- Multiple venting options
 - Category II or IV
 - Allows differential pressure zones for intake air and exhaust
 - Sealed combustion
 - Direct vent
 - Common venting of multiple boilers
- Seismic restraint base assembly
- HeatNet integrated boiler management system
- Modbus protocol for BMS communications
- Turbo Pilot (patent-pending design)
- Honeywell RM7800 Series flame safeguard

OPTIONAL FEATURES

- Cupro-Nickel Finned Tubes
- Freeze protection package
- BACnet or LonWorks interface module
- Honeywell keyboard display module S7800
- Outdoor sensor with housing

Efficiency vs. Return Water Temperature

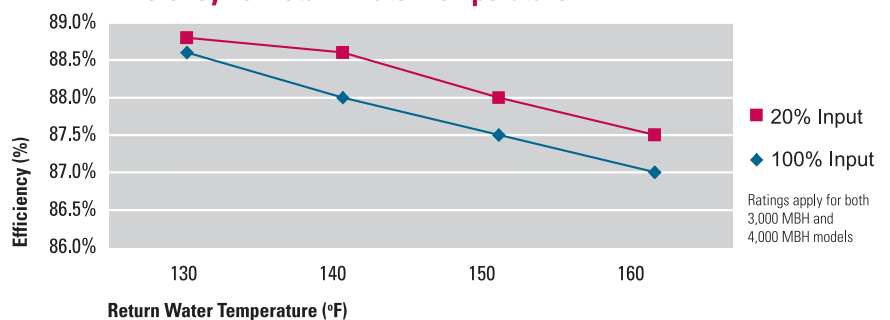

DEPENDABLE, EFFICIENT PERFORMANCE

- High efficiency, up to 88%
- Full modulation with smooth, 5:1 turndown
- Sealed combustion/direct vent
- Symmetrically air/fuel coupled
- Commercial-quality combustion controls
- Linked operating control system for multiple unit applications
- Gasketless heat exchanger assembly
- Low NOx

A Small Step that Makes Big Plans Possible

The demands of the market change—more energy efficiency, less mechanical room space—and your plans need to change with them. Making a sizable difference in this evolving market is difficult. But the latest innovation from RBI will bring your project's design challenges down to size.

We take pride in engineering a higher degree of performance from our boilers and water heaters. But what architects, engineers, installers, and building owners take from it is something else entirely: a better way to get their job done.

With the Futera XLF, a new level of performance will help change the way mechanical room space is planned for—and how domestic hot water and hydronic heat load is accounted for.



FUTERA XLF

Dimensions & Ratings

NOTE: Dimensions are approximate and should not be used to "rough-in" equipment.

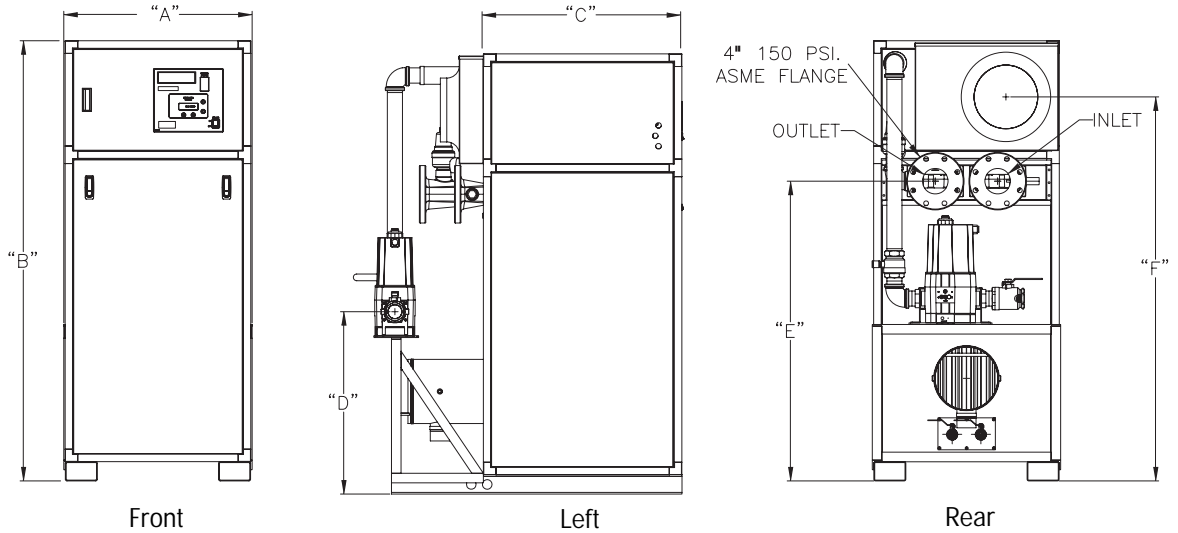

Model	A		B		C		D		E		F	
	In.	cm	In.	cm	In.	cm	In.	cm	In.	cm	In.	cm
3000	29 ¹ / ₂	74.9	60	152.4	31 ¹ / ₈	79.1	19 ⁵ / ₈	49.9	37 ¹⁵ / ₁₆	96.4	51 ¹ / ₈	129.9
4000	29 ¹ / ₂	74.9	69	175.3	31 ¹ / ₈	79.1	28 ⁵ / ₈	72.7	46 ¹⁵ / ₁₆	119.2	60 ¹ / ₈	152.7

MB/MW 3000

Dimensions & Ratings

Input (MBH / kW)	3000 / 879
Output (MBH / kW)	2610 / 765
Flue Vent	8"
Air Intake	8"
Gas Connection	2"
Water Connection	4"
Weight (Lbs / Kg)	1023 / 464

Hourly Recovery Capacity ΔT (GPH & LPG)

40° F	7833	22° C	29652
60° F	5222	33° C	19768
80° F	3917	44° C	14826
100° F	3133	56° C	11861
120° F	2611	67° C	9884
140° F	2238	78° C	8472

Temperature Rise / Pressure Drop

20° F / 11.1° C	Flow Rate (GPM / L/s)	261.0 / 16.5
	Pressure Drop (Ft / kPa)	15.20 / 44.7
25° F / 13.9° C	Flow Rate (GPM / L/s)	208.8 / 13.2
	Pressure Drop (Ft / kPa)	9.73 / 28.7
30° F / 16.7° C	Flow Rate (GPM / L/s)	174.0 / 11.0
	Pressure Drop (Ft / kPa)	6.75 / 19.9
35° F / 19.4° C	Flow Rate (GPM / L/s)	149.1 / 9.4
	Pressure Drop (Ft / kPa)	2.80 / 14.6

MB/MW 4000

Dimensions & Ratings

Input (MBH / kW)	4000 / 1172
Output (MBH / kW)	3480 / 1020
Flue Vent	10"
Air Intake	10"
Gas Connection	2"
Water Connection	4"
Weight (Lbs / Kg)	1223 / 555

Hourly Recovery Capacity ΔT (GPH & LPG)

40° F	10444	22° C	39536
60° F	6963	33° C	26357
80° F	5222	44° C	19768
100° F	4178	56° C	15814
120° F	3481	67° C	13179
140° F	2984	78° C	11296

Temperature Rise / Pressure Drop

20° F / 11.1° C	Flow Rate (GPM / L/s)	348.0* / 22.0
	Pressure Drop (Ft / kPa)	27.00 / 79.5
25° F / 13.9° C	Flow Rate (GPM / L/s)	278.4 / 17.6
	Pressure Drop (Ft / kPa)	17.30 / 51.0
30° F / 16.7° C	Flow Rate (GPM / L/s)	232.0 / 14.6
	Pressure Drop (Ft / kPa)	12.00 / 35.4
35° F / 19.4° C	Flow Rate (GPM / L/s)	198.9 / 12.5
	Pressure Drop (Ft / kPa)	8.80 / 25.9

*Flow exceeds recommended maximum; use a greater temperature rise or consult manufacturer. Cupronickel heat exchanger should be considered.